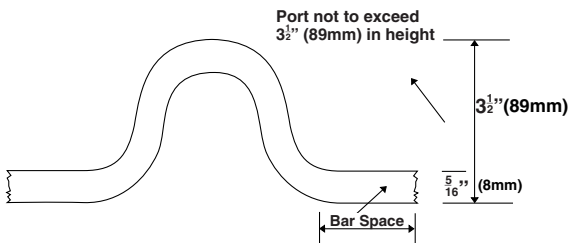
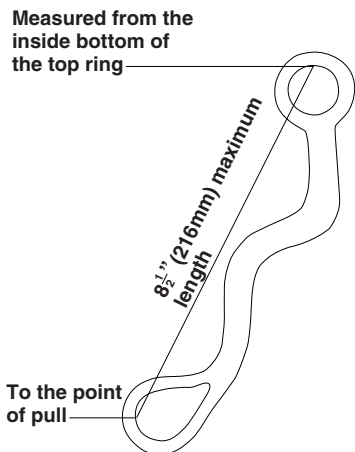
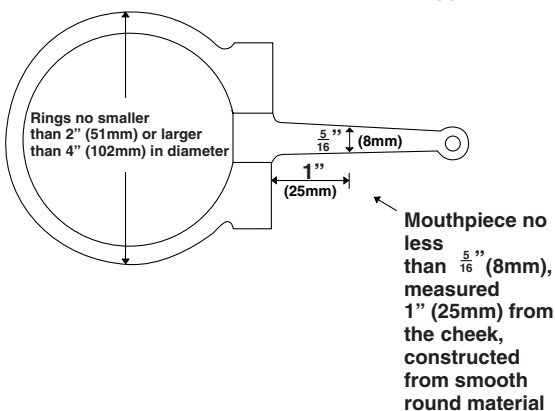


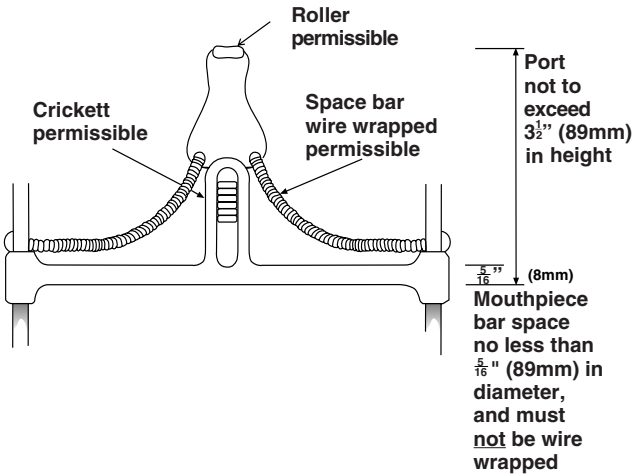
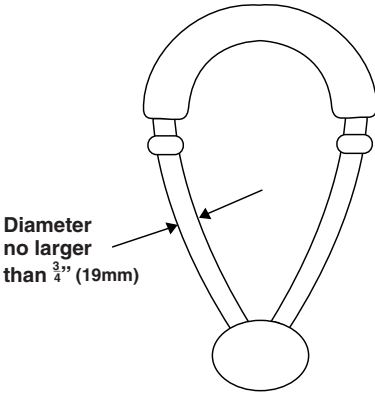
**Figure #1 - Bit Measurements**



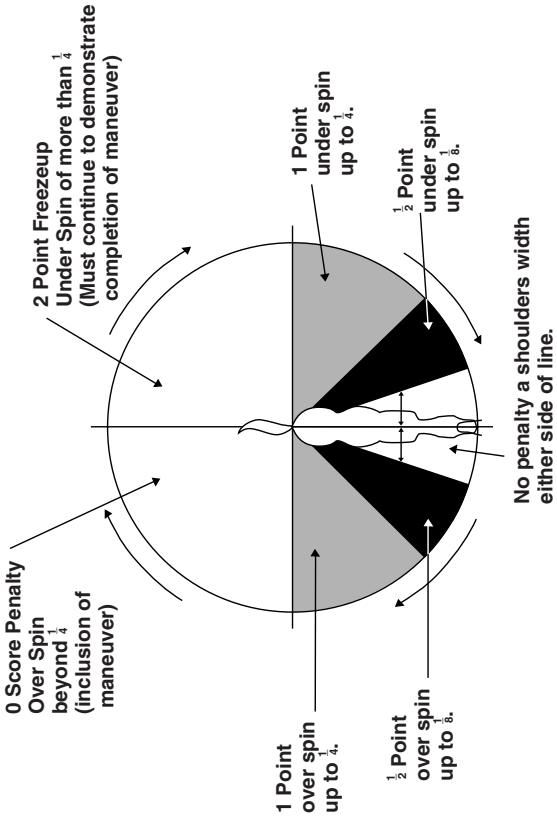
Mouthpiece bar space no less than  $\frac{5}{16}$ " (8mm) in diameter, and must not be wire wrapped



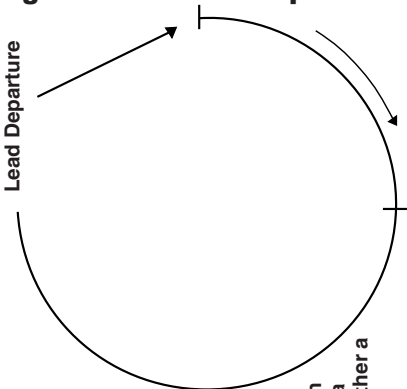
**Figure #2 - Bit Measurements**



**Figure #3A - Over/Under Spin**

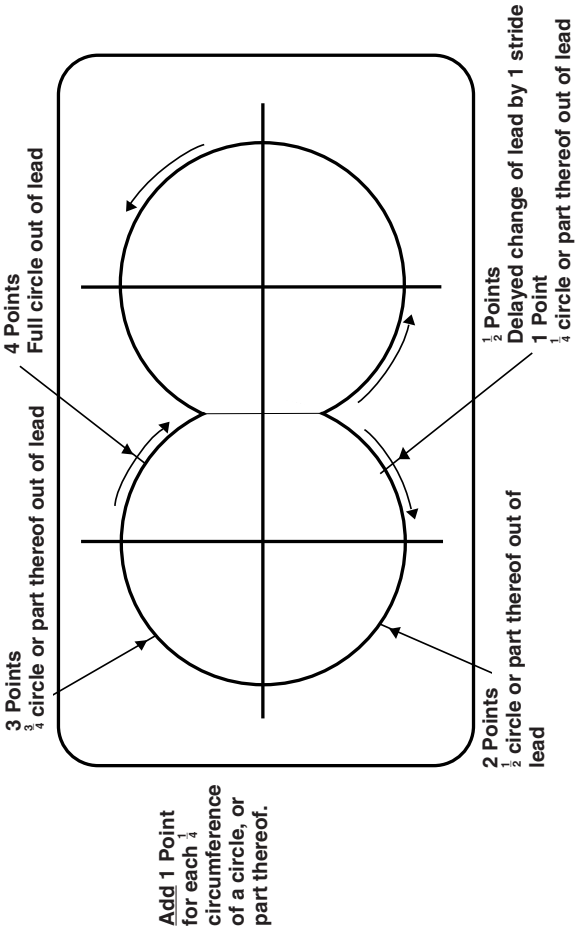


**Figure #3B - Lead Departure**

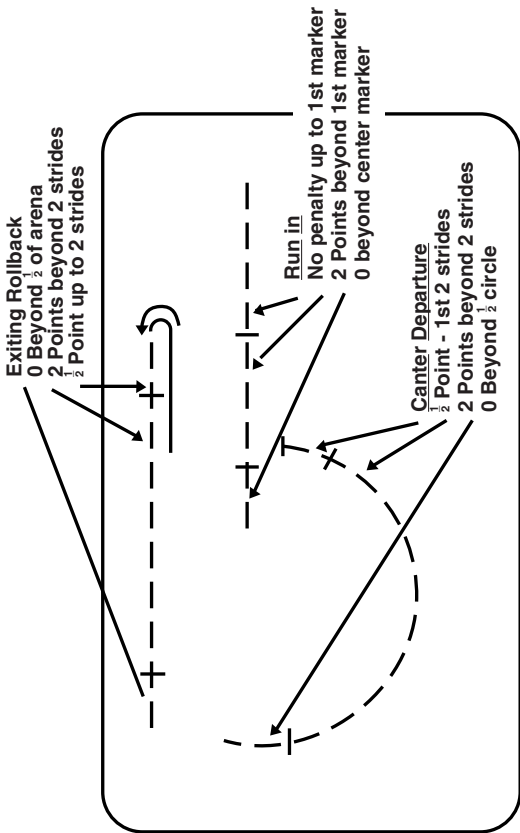


Stopping in the first  $\frac{1}{4}$  circumference of a circle after a canter departure is NOT to be considered an inclusion on a maneuver, rather a break of gait penalty shall apply.

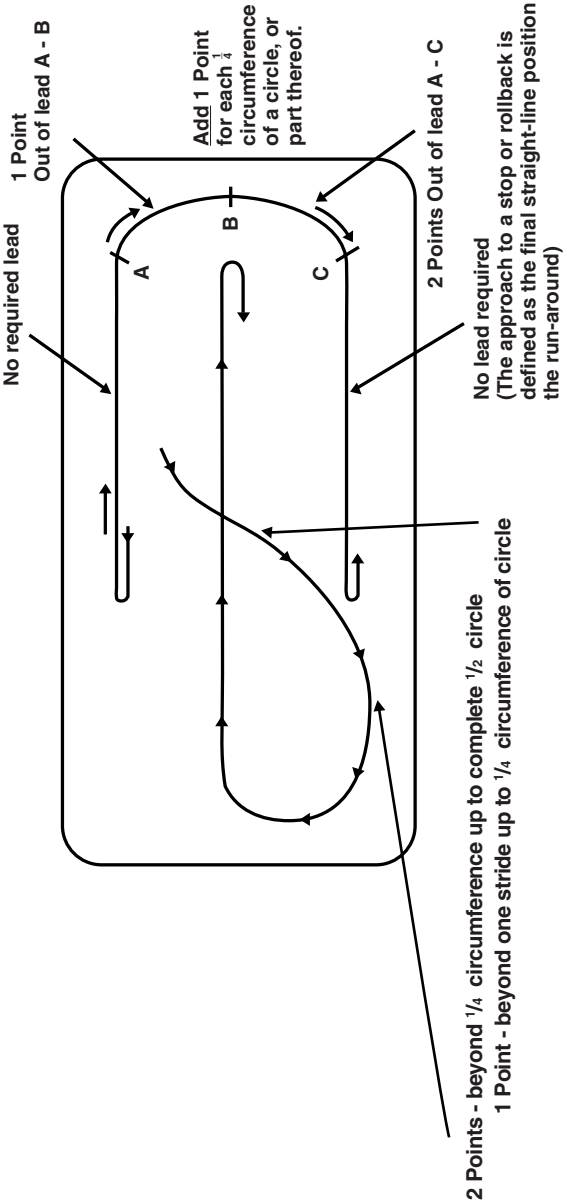
**Figure #4 - Out of Lead/Delayed Change**



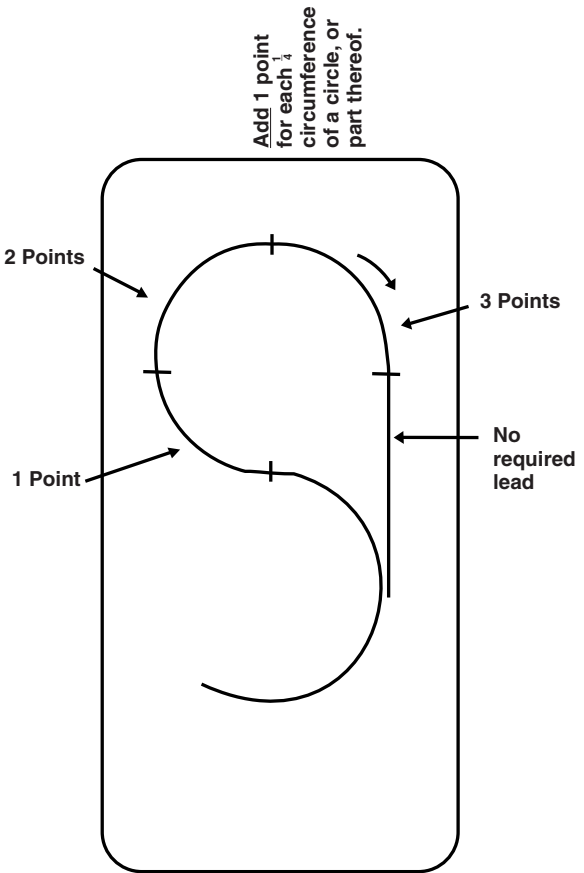
**Figure #5 - Jogging**



**Figure #6 - Out of Lead on Run-around**



**Figure #7 - Out of Lead on Partial Circle Leading to Run-down**



### Figure #8 - Sample Score Card

**NRHA JUDGES SCORE CARD**

Event \_\_\_\_\_ Date \_\_\_\_\_ Class \_\_\_\_\_ Pattern 4  
 Judge \_\_\_\_\_

MANEUVER SCORES: -1/2 Extremely Poor -1 Very Poor -1/2 Poor 0 Correct +1/2 Good +1 Very Good +1 1/2 Excellent

DRAW	EXH #	MANEUVER DESCRIPTION	PENALTY TOTAL								SCORE	
			1	2	3	4	5	6	7	8		
1	256		0	+1/2	+1/2	-1/2	0	+1/2	+1/2	+1/2	1 1/2	70 1/2
2	143		-1/2	0	-1	-1/2	0	+1/2	0	0	0	0
3	210		+1/2	1/2	+1/2	+1	0	+1/2	+1	+1/2	1	75
4	178											
5	120											

### Figure #9 Sample Freestyle Score Card

**Freestyle Reining**  
**NRHA JUDGES SCORE CARD**

Event \_\_\_\_\_ Date \_\_\_\_\_ Class FREESTYLE  
 Judge \_\_\_\_\_

MANEUVER SCORES: -11/2 Extremely Poor 1 Very Poor -1/2 Poor 0 Correct +1/2 Good +1 Very Good +11/2 Excellent

DRAW	EXH#	MANEUVER DESCRIPTION	PENALTY TOTAL								SCORE	
			1	2	3	4	5	6	7	8		
1	256	Required Score Additional Maneuvers	+1/2 0	0 0	+1/2 0	0 0	+1/2 +1/2	+1/2 +1/2	+1/2 +1/2	0 +1/2 +1/2	Artistic	73
2	307	Required Score Additional Maneuvers	0 -1/2	-1/2 -1/2	0 0	0 0	0 -1/2	-1/2 -1/2	0 -1/2	-1/2 -1/2	Artistic	65 1/2
		Required Score Additional Maneuvers									Artistic	
		Required Score Additional Maneuvers									Artistic	

MANEUVER SCORES: -11/2 Extremely Poor 1 Very Poor -1/2 Poor 0 Correct +1/2 Good +1 Very Good +11/2 Excellent

Judge's Signature \_\_\_\_\_